

**TECNO**

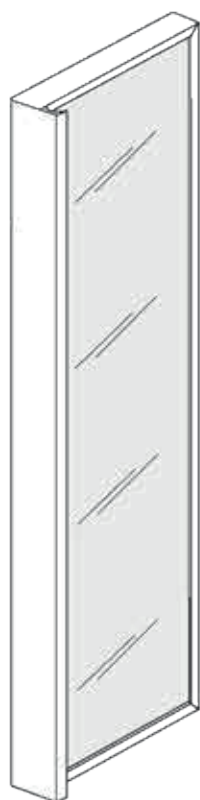

BATTENTE  
HINGED

PIEGHEVOLE  
FOLDING

ALTEZZE - HEIGHT

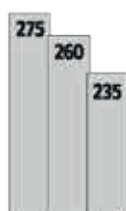

LARGHEZZE - WIDTH  
cm. 39,4 - 47,2 - 63,2

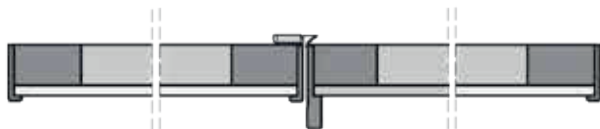

Anta non utilizzabile  
su colonne terminali e angolo.

*Hinged door unusable on terminal  
columns and corner.*



**TECNO**

Anta con telaio in estruso di alluminio e bordo perimetrale a vista di mm. 8, con montante verticale più sporgente per impugnatura, sporgenza mm. 16, spessore anta mm. 25.

finiture telaio:  
alluminio naturale, piombo,  
bronzo, laccato opaco.

finiture pannello:  
vetro trasparente, acidato, specchio,  
vetro laccato o extra.

*Extruded aluminium frame door  
with 8 mm. exposed frame edge,  
with handle-like protruding  
upright 16 mm,  
door thickness 25 mm.*

*frame finishes:  
natural aluminium, lead,  
bronze, matt lacquered.*

*panel finishes:  
transparent, etched glass, mirror,  
lacquered or extra glass.*

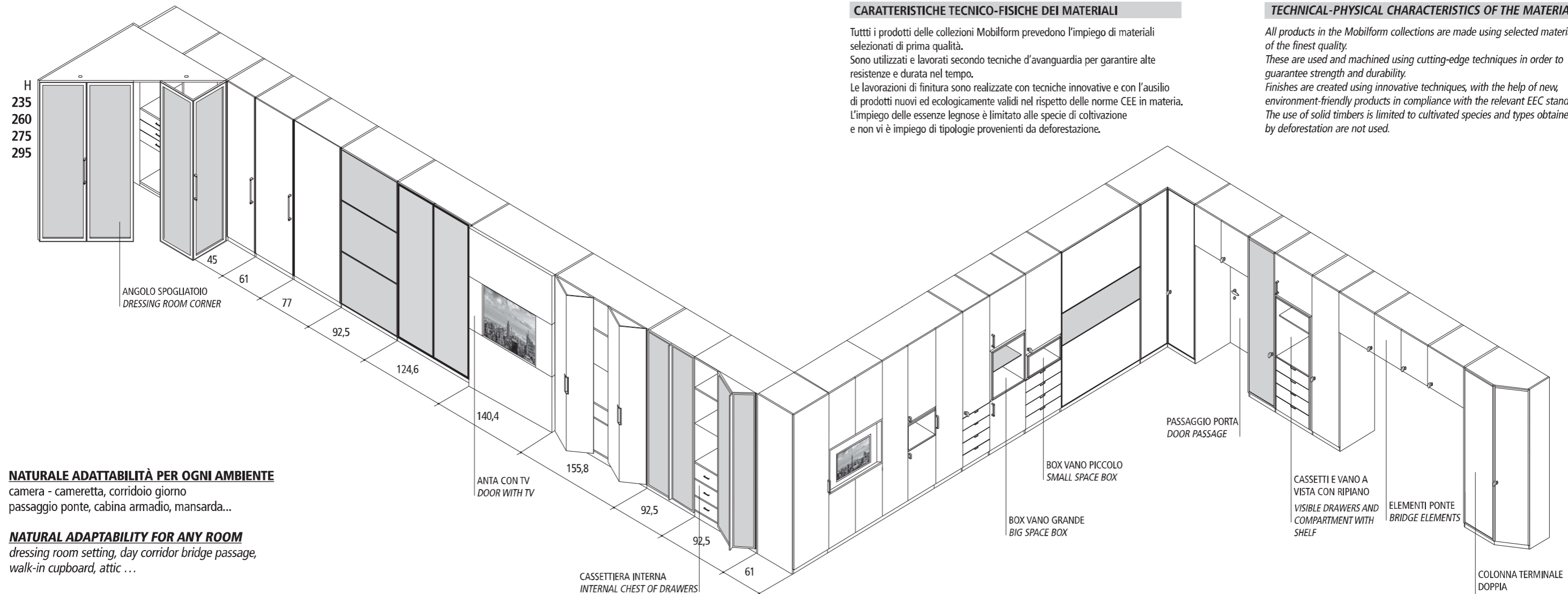

**NATURALE ADATTABILITÀ PER OGNI AMBIENTE**

camera - cameretta, corridoio giorno  
passaggio ponte, cabina armadio, mansarda...

**NATURAL ADAPTABILITY FOR ANY ROOM**

dressing room setting, day corridor bridge passage,  
walk-in cupboard, attic ...

**INFINITA POSSIBILITÀ COMPOSITIVA**

8 larghezze, 4 altezze, 3 tipologie terminali,  
colonne per angoli, colonne a giorno, colonne ponte.

**INFINITE COMPOSITION OPTIONS**

8 widths, 4 heights, 3 end types, corner columns,  
day columns, bridge columns.

**4 TIPOLOGIE DI APERTURA ABBINABILI TRA LORO**

battente, pieghevole, scorrevole, complanare.

**4 TYPES OF COMBINABLE**

opening hinged, folding, sliding, co-planar.

**AMPIA GAMMA DI FINITURE ESTERNE**

30 laccature, rovere sbiancato/tabacco/grigio/termo, noce canaletto,  
rovere laccato poro aperto, larice laccato poro aperto,  
21 tipologie di vetri, rivestimenti, tessuti, carta da parati

**EXTENSIVE RANGE EXTERNAL FINISHES**

30 lacquering, bleached/tobacco/grey/termo oak, canaletto walnut,  
open-pore lacquered oak, open-pore lacquered larch,  
21 types of glasses, finishes, fabrics, wallpaper

**6 DIVERSE FINITURE INTERNE**

Nobilitato nobiltex, larice bianco, rovere cenere,  
noce canaletto, larice brown e nobileather.

**6 DIFFERENT INTERIORS**

Nobiltex, white larch, ash oak, canaletto walnut,  
brown larch, nobileather melamine.

**MOLTEPLICI ATTREZZATURE INTERNE**

cassettiere, vassoi portacamicie-porta maglioni,  
portacravatte, servetti, specchi estraibili, portascarpe etc...

**MANY INTERNAL FITTINGS**

chests of drawers, shirt drawers - trouser rack, tie rack,  
pull-down hangers, extractable mirrors, shoe racks, etc...

**INNUMEREVOLI INTERVENTI A MISURA**

riduzione in altezza, profondità e larghezza, taglio mansardato,  
taglio per colonne, tamponamenti a muro.

**INNUMERABLE CUSTOMISED JOBS**

height depth and width reductions, attic cut,  
cutting for columns, butting against walls.

**CARATTERISTICHE TECNICO-FISICHE DEI MATERIALI**

Tutti i prodotti delle collezioni Mobilform prevedono l'impiego di materiali  
selezionati di prima qualità.

Sono utilizzati e lavorati secondo tecniche d'avanguardia per garantire alte  
resistenze e durata nel tempo.

Le lavorazioni di finitura sono realizzate con tecniche innovative e con l'ausilio  
di prodotti nuovi ed ecologicamente validi nel rispetto delle norme CEE in materia.

L'impiego delle essenze legnose è limitato alle specie di coltivazione  
e non vi è impiego di tipologie provenienti da deforestazione.

**TECHNICAL-PHYSICAL CHARACTERISTICS OF THE MATERIALS**

All products in the Mobilform collections are made using selected materials  
of the finest quality.

These are used and machined using cutting-edge techniques in order to  
guarantee strength and durability.

Finishes are created using innovative techniques, with the help of new,  
environment-friendly products in compliance with the relevant EEC standards.

The use of solid timbers is limited to cultivated species and types obtained  
by deforestation are not used.

**VASTE TIPOLOGIE DI MANIGLIE E CHIAVI**

coordinate per estetica e finitura delle ante del sistema Metros in legno,  
metallo, rivestite in cuoio e tecnopelle.

**VAST RANGE OF TYPES OF HANDLES AND  
COORDINATED KEYS**

for the aesthetics and finish on the doors for the Metros system in wood,  
metal, covered in leather and in eco-leather.

**4 ALTEZZE**

235 - 260 - 275 - 295. Altre altezze al taglio.  
Con ante scorrevoli l'altezza dell'armadio è maggiore di 2 cm, rispetto  
alle dimensioni in altezza della scocca a causa del carrello superiore  
dell'anta sporgente.

**4 HEIGHTS**

235 - 260 - 275 - 295. Other heights can be cut.  
When sliding doors are used the wardrobe is 2 cm higher than the height  
of the chassis, due to the upper carriage for the protruding door.

**8 LARGHEZZE**

37,2 - 45 - 61 - 77 - 92,5 - 124,6 - 140,4 - 155,8. Altre larghezze al taglio.

**8 WIDTHS**

37,2 - 45 - 61 - 77 - 92,5 - 124,6 - 140,4 - 155,8. Other widths can be cut.

**CAPPELLO E BASAMENTO**

di spessore cm 2,5 sono dotati di guarnizione  
parapolvere per la battuta ante. Basamento dotato di piedini regolabili.

**CAPPING AND BASE**

2,5 cm thick fitted with a dust seal in the door closing area.  
Base fitted with adjustable feet.

**SPALLE INTERNE ED ESTERNE**

spessore 2,5 cm, forati ogni 12,8 cm,  
per posizionamento ripiani.  
Spalle laterali dotate di profilo anteriore.

**INTERNAL AND EXTERNAL SIDES**

2.5 cm thick, drilled every 12,8 cm  
for shelf positioning.  
Side panels with a front profile.

**RIPIANI INTERNI-SCHIENALI**

Spessore 2,5 o 3,5 cm, e spostabili ogni 12,8 cm.  
Schienale spessore 0,8 cm.

**INTERNAL SHELVES - BACKS**

2.5 or 3,5 cm thick, and adjustable every 12,8 cm.  
Back 0.8 cm thick.

RIDUZIONE DEGLI ELEMENTI IN PROFONDITÀ PER PARETI CON PILASTRO.

REDUCED DEPTH OF ELEMENTS FOR WALLS WITH COLUMNS.

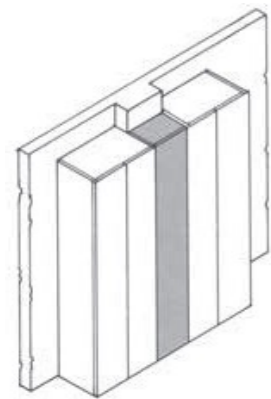

CAMBIO DI PROFONDITÀ MANTENENDO L'ALLINEAMENTO FRONTALE DELLE ANTE.

CHANGE IN DEPTH MAINTAINING THE FRONT ALIGNMENT OF THE DOORS.

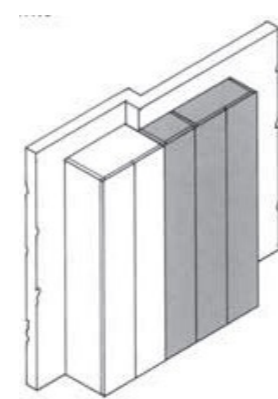

SOLUZIONE PONTE. IN VARIE ALTEZZE E LARGHEZZE PER INSERIMENTO LETTI, DIVANI E ELEMENTI SCRITTOIO.

BRIDGE SOLUTION IN VARIOUS HEIGHTS AND WIDTHS FOR INCLUSION BEDS, SOFAS AND WRITING-DESKS.

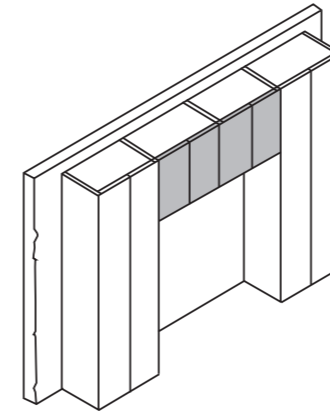

PASSAGGI PONTE-PORTA.

BRIDGE-DOOR PASSAGES.

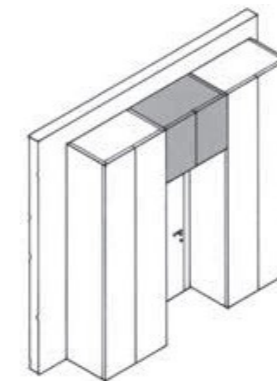

ARMADIO CON ELEMENTI TERMINALI TRAPEZIOIDALI A 30 O 45 GRADI.

WARDROBE WITH TRAPEZOIDAL END ELEMENTS AT 30 OR 45 DEGREES.

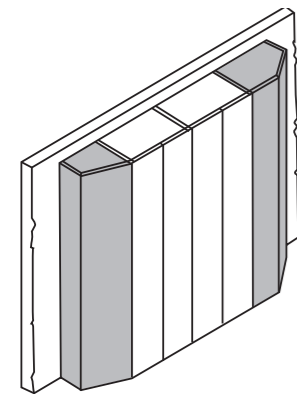

SITUAZIONE ANGOLARE CON ACCOSTAMENTO DI DUE COLONNE.

CORNER SITUATION WITH A COMBINATION OF 2 COLUMNS.

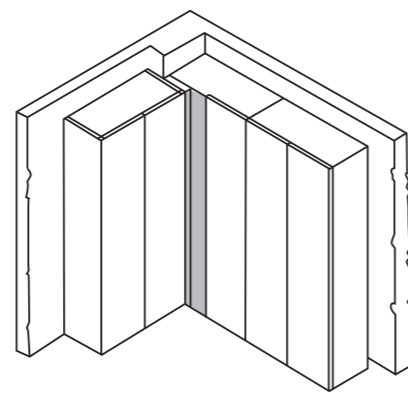

ARMADIO CON TAGLIO PER MANSARDA.

WARDROBE CUT FOR ATTIC.

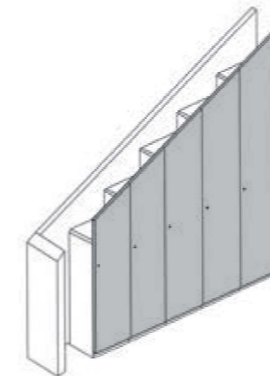

ARMADI AD ALTEZZE DIFFERENZIATE PER SOLUZIONI A MANSARDA.

WARDROBES OF DIFFERENT HEIGHTS FOR ATTIC SOLUTIONS.

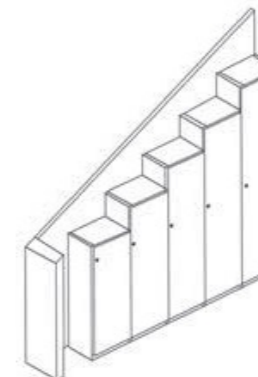

ELEMENTI ANGOLARI COMPLETAMENTE SFRUTTABILI.

FULLY USABLE CORNER ELEMENTS.

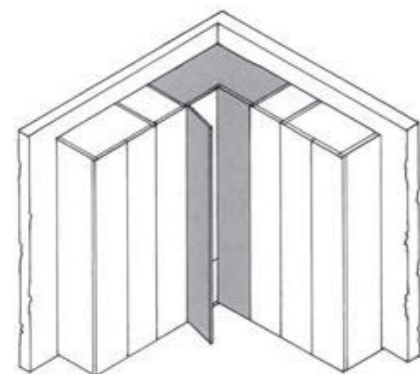

SITUAZIONE ANGOLARE OTTENUTA CON LESENA D'ANGOLO.

CORNER SITUATION OBTAINED WITH CORNER PILASTER.

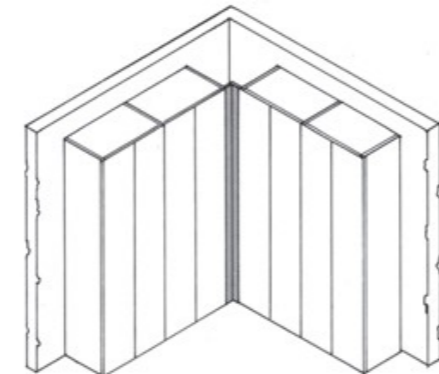

POSSIBILITÀ DI AVERE LA STRUTTURA DI SERIE CON ANTE DI ALTEZZA SUPERIORE A MISURA (SOLO ANTE BATTENTI).

STANDARD STRUCTURE AVAILABLE WITH HIGHER DOORS TO MEASURE (HINGED DOORS ONLY).

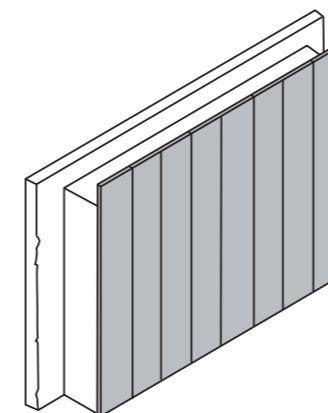

RIDUZIONE DEGLI ELEMENTI IN ALTEZZA, LARGHEZZA E PROFONDITÀ.

ELEMENTS REDUCED IN HEIGHT, WIDTH, AND DEPTH.

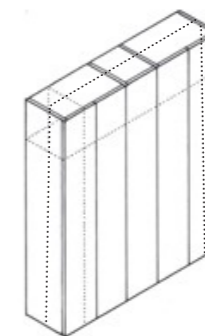

FASCE DI TAMPONAMENTO SOFFITTO E PARETE.

CEILING AND WALL BUTTING STRIPS.

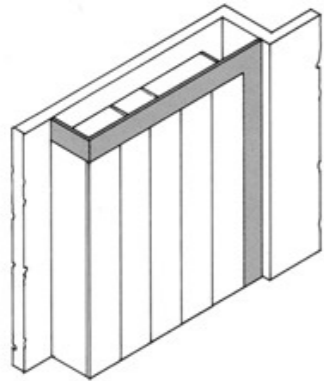

CHIUSURA LATERALE APRIBILE A RIPOSTIGLIO.

SIDE CLOSING WITH STORAGE ROOM OPENING.

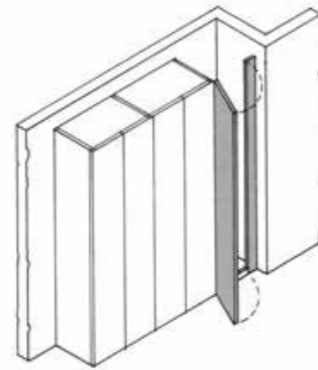

ARMADIO CON TERMINALE SPOGLIATOIO DX O SX.

WARDROBE WITH LT OR RT DRESSING ROOM END.

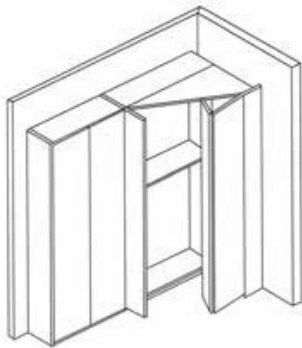

ARMADI CON ABBINAMENTO DI APERTURE SCORREVOLI, BATTENTE O PIEGHEVOLE.

WARDROBES WITH SLIDING, HINGED OR FOLDING DOOR OPENING MATCHING.

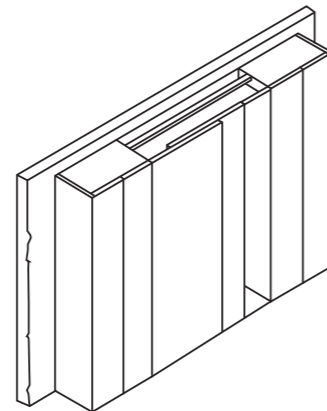

POSSIBILITÀ ABBINAMENTI PROGETTUALI CON SISTEMA CABINA ARMADIO LIBERA.

OPTIONS DESIGN COMBINATION WITH LIBERA WALK-IN CLOSET.

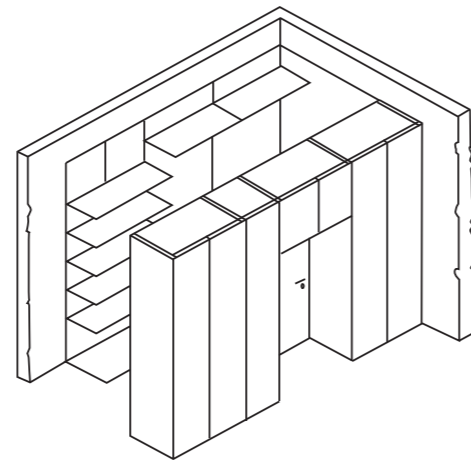
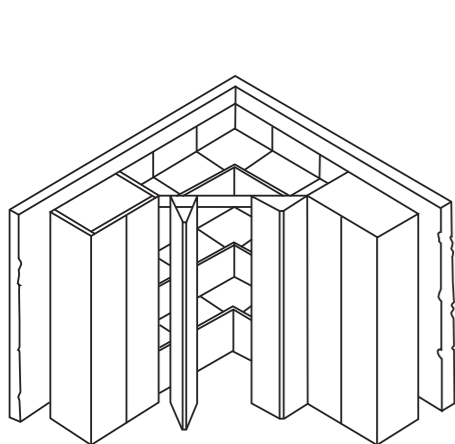

ELENCO ELEMENTI STRUTTURALI

Spalle, basamenti e coperchi spessore cm. 2,5.  
Ripiani spessore cm. 2,5 o 3,5.  
6 diverse finiture: nobilitato nobiltex, nobilitato larice bianco, nobilitato rovere cenere, nobilitato noce canaletto, nobilitato larice brown e nobilitato nobileather.  
Schienali realizzati in nobilitato spessore mm 8.

LIST OF STRUCTURAL ELEMENTS

Sides, bases and tops thick 2,5 cm.  
Shelves thick 2,5 or 3,5 cm.  
6 different finishes: nobiltex melamine, white larch melamine, ash oak melamine, canaletto walnut melamine, larch brown melamine and nobileather melamine.  
Back realized in melamine thick 8 mm.

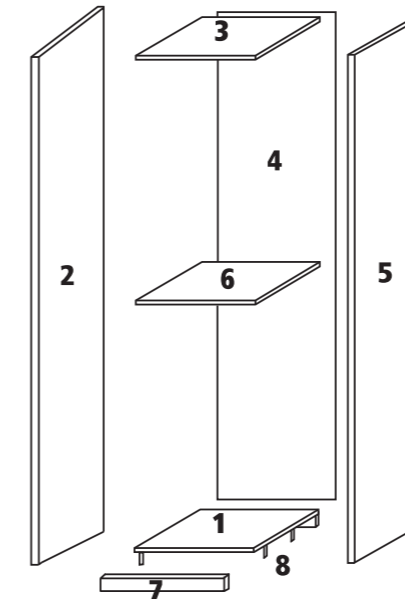

- 1 - BASAMENTI spessore cm. 2,5 in 8 larghezze  
BASES thick 2,5 cm. in 8 widths
- 2 - SPALLA LATERALE spessore cm. 2,5 in 4 altezze  
LATERAL SIDE thick 2,5 cm. in 4 heights
- 3 - CAPPELLO spessore cm. 2,5 in 8 larghezze  
TOP thick 2,5 cm. in 8 widths
- 4 - SCHIENALE spessore mm. 8 mm.  
BACK thick 8 mm.
- 5 - SPALLA CENTRALE spessore cm. 2,5 in 4 altezze  
CENTRAL SIDE thick 2,5 cm. in 4 heights
- 6 - RIPIANI INTERNI spessore cm. 2,5 o 3,5 in 8 larghezze  
INTERNAL SHELVES 2,5 or 3,5 thick cm. in 8 widths
- 7 - ZOCCOLO ALLUMINIO VERNICIATO, PIOMBO O LACCATO altezza cm. 3/6.  
LEAD OR LACQUERED ALLUMINIUM PLINTH height 3/6 cm.
- 8 - PIEDINO REGOLABILE  
ADJUSTABLE FOOT

SPALLE LATERALI

Le spalle laterali spessore cm. 2,5 degli armadio con anta battente o pieghevole possono essere personalizzate da un massello frontale fornito nella stessa finitura della facciata oppure senza massello con predisposizione per installazione fascia filo anta.

SIDE PANELS

The 2,5 cm thick side panels of the wardrobe with swing or folding door can be personalised by means of a solid-wood front featuring the same finish as the front or without solid-wood but ready for fitting door flush strip.

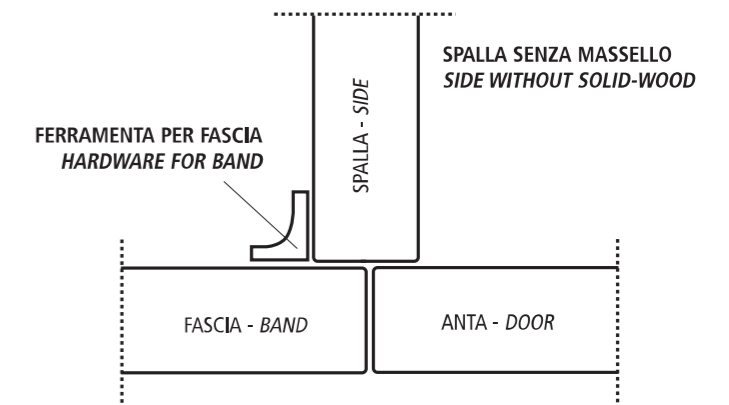
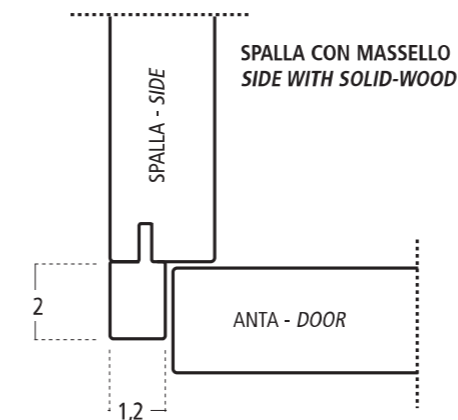

**ANTA BATTENTE E PIEGHEVOLE spessore 25 mm.**  
**HINGED AND FOLDING DOORS width 25 mm.**

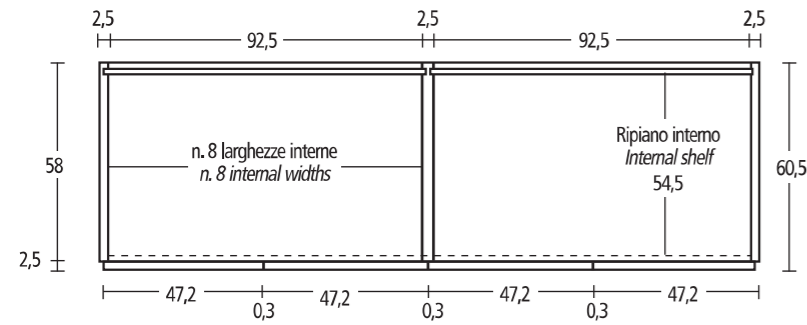

**TERMINALE SINGOLO CON SMUSSO A 45° O 30° - TERMINALE DOPPIO CON SMUSSO A 30°**  
**SINGLE END WITH 40° AND 30° BEVEL - DOUBLE END WITH 30° BEVEL.**

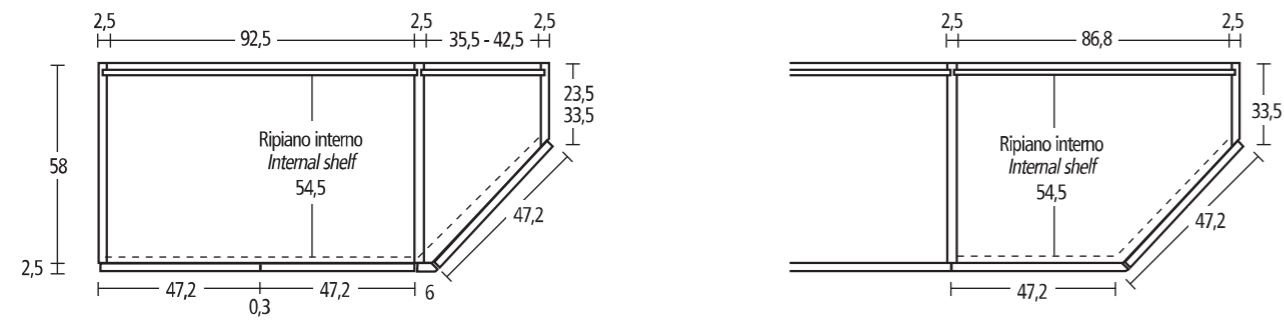

**ANGOLO ANTA BATTENTE**  
**HINGED DOOR CORNER**

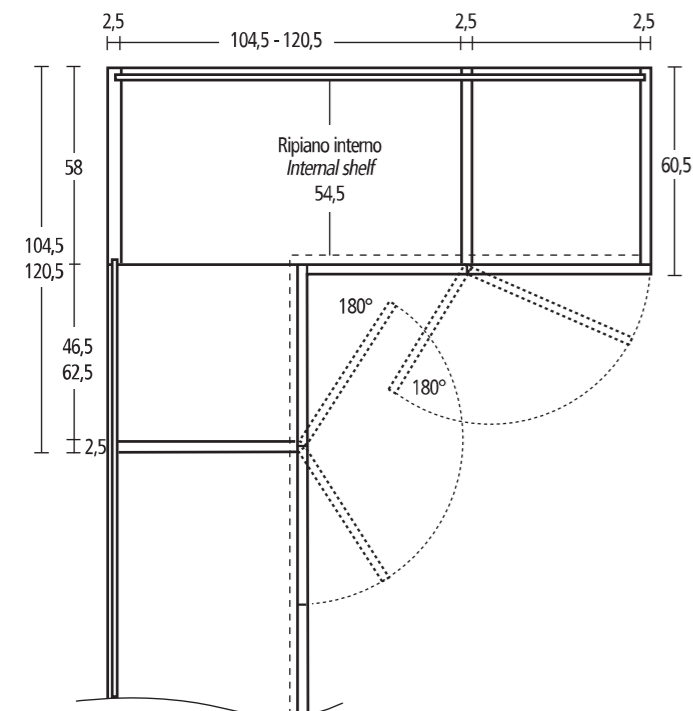

**ANTA BATTENTE-PIEGHEVOLE spessore 25 mm.**  
**HINGED-FOLDING DOORS thick 25 mm.**

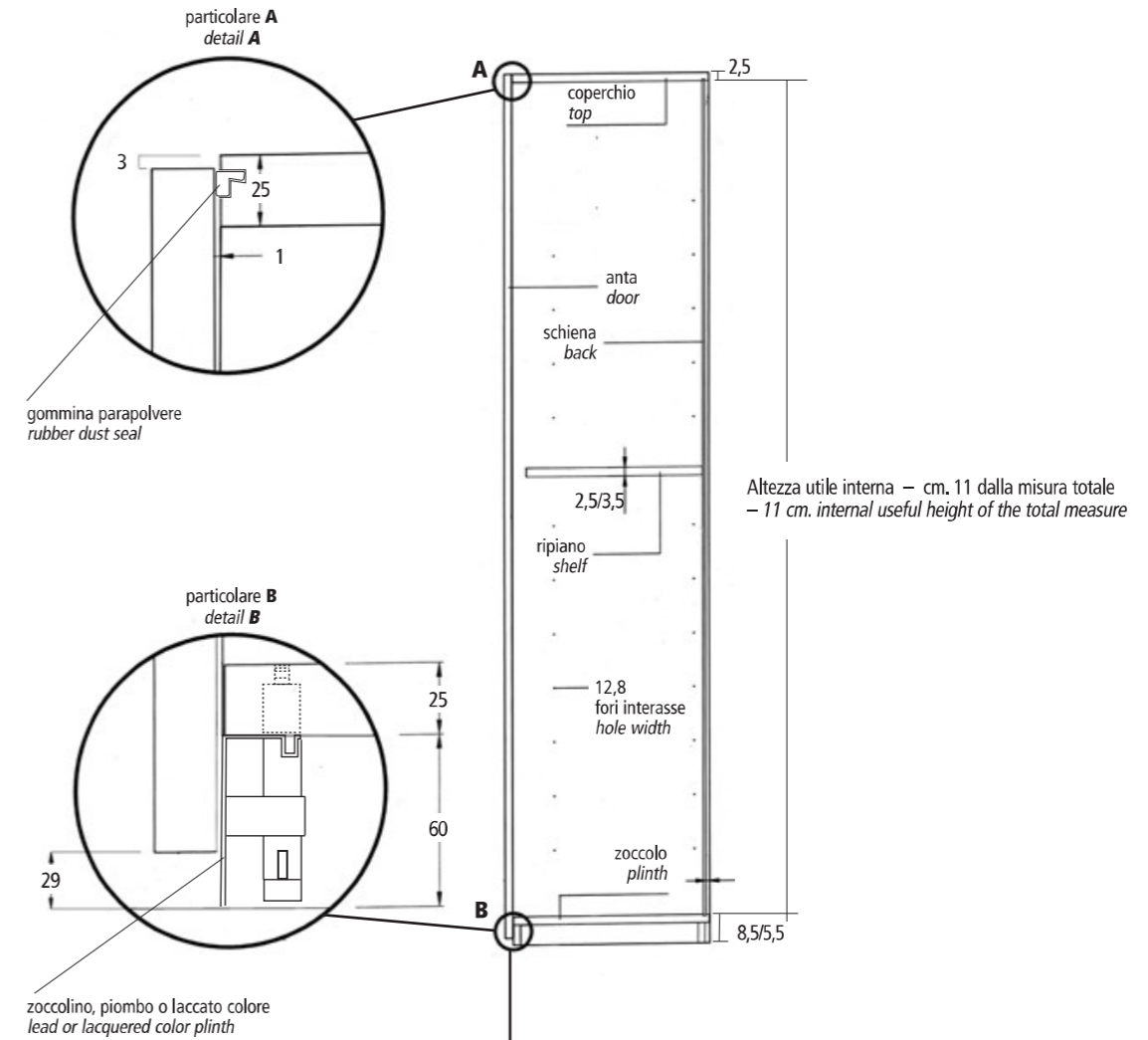

particolare B per ANTA VIEW, METROS e CABINA ARMADIO  
detail B for VIEW DOOR, METROS and WALK-IN CLOSET

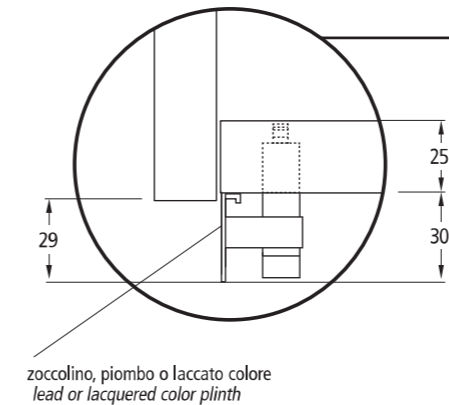

**SPAZI NECESSARI PER MONTAGGIO**  
**IMPORTANT:** Per il montaggio di armadi in nicchia richiedere ferramenta speciale e ricordarsi che occorrono comunque almeno cm. 2 per l'inserimento dello schienale.

**ROOM REQUIRED FOR FITTING**  
**IMPORTANT:** To fit wardrobes in recesses ask for special hardware and remember that at least 2 cm. are required to fit the back.

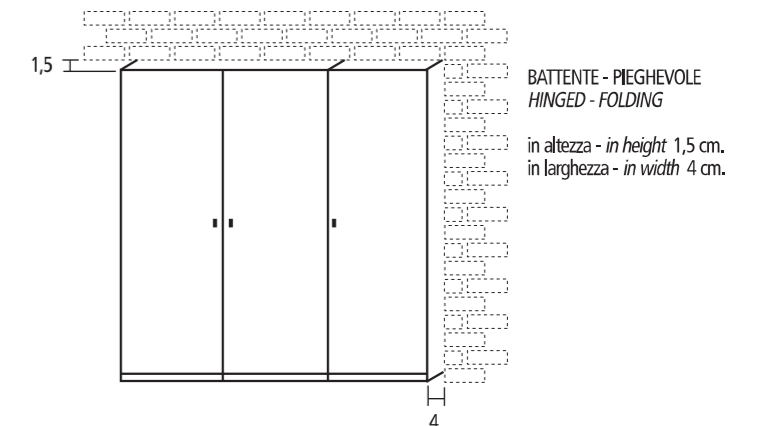

BATTENTE - PIEGHEVOLE  
HINGED - FOLDING  
in altezza - in height 1,5 cm.  
in larghezza - in width 4 cm.

**ANTA SCORREVOLE spessore 25 mm.**  
**SLIDING DOOR thick 25 mm.**

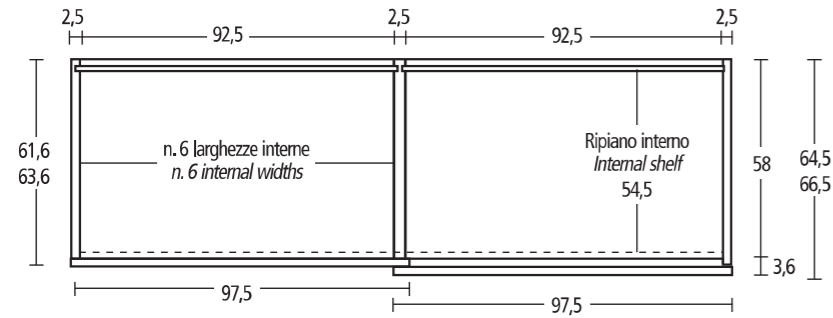

**ANTA SCORREVOLE PER ANTA PLANA**  
**SLIDING DOOR FOR PLANA DOOR**

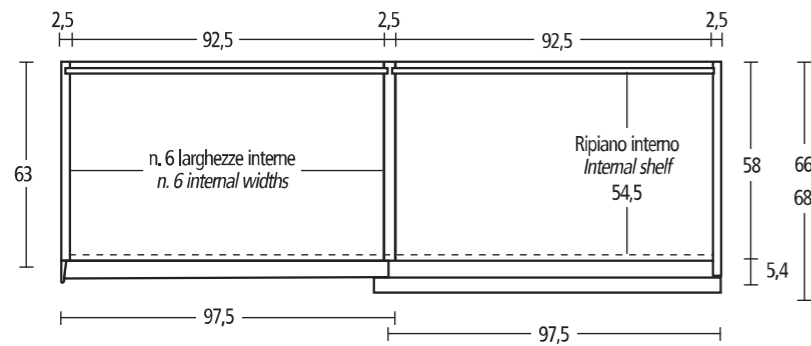

**ARMADIO ANGOLO CON ANTA SCORREVOLE**  
**CORNER WARDROBE WITH SLIDING DOOR**

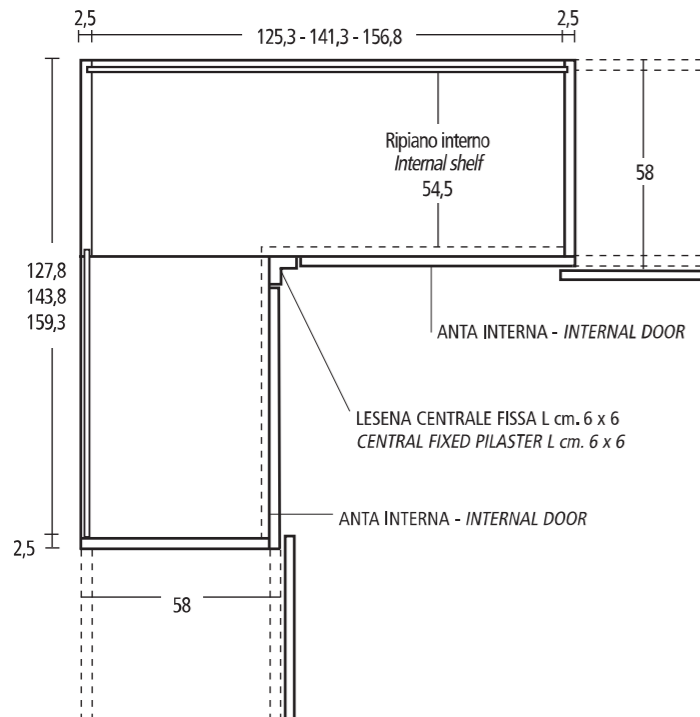

**SORMONTI SPALLA LATERALE ARMADIO ANTE SCORREVOLI**  
**OVERLAPS LATERAL SIDE SLIDING DOOR WARDROBE**

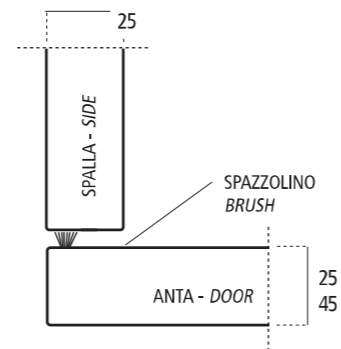

**ANTA SCORREVOLE**  
**SLIDING DOORS**

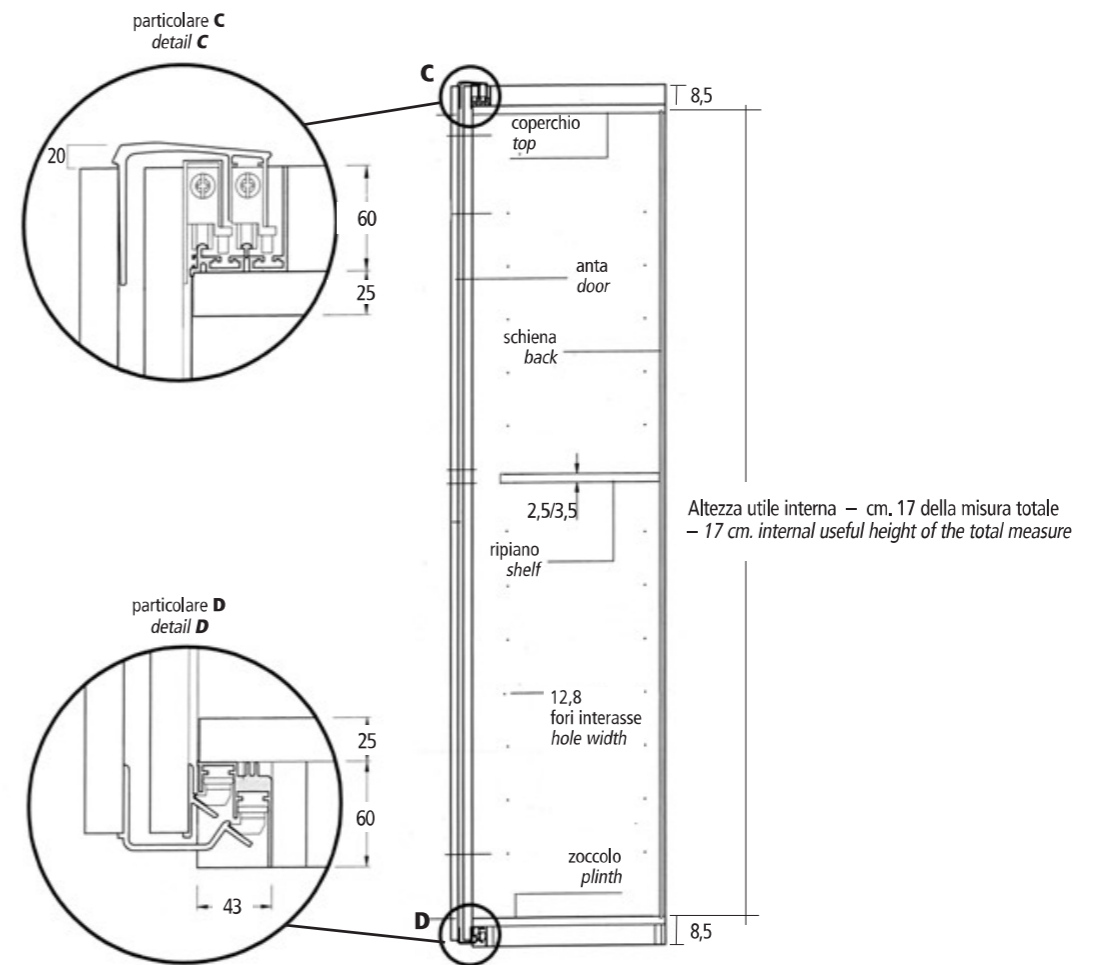

**SPAZI NECESSARI PER MONTAGGIO**

IMPORTANTE: Per il montaggio di armadi in nicchia richiedere ferramenta speciale e ricordarsi che occorrono comunque almeno 2 cm. per l'inserimento dello schienale.

**ROOM REQUIRED FOR FITTING**

IMPORTANT: To fit wardrobes in recesses ask for special hardware and remember that at least 2 cm. are required to fit the back.

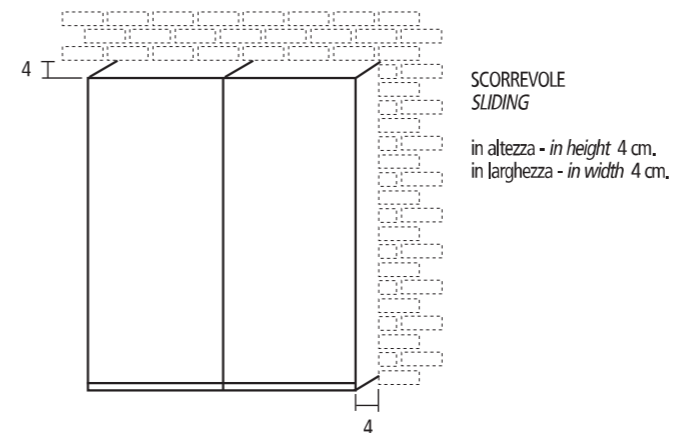

NOBILITATI strutture armadio - cabine - MELAMINE wardrobe - cabinets structure

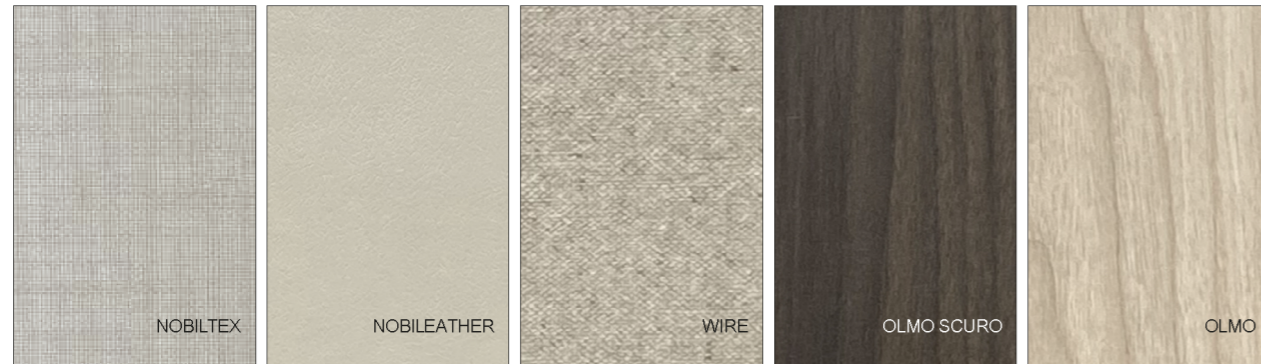

NOBILITATI ante - MELAMINE doors (SINTESI - NOBILEATHER - NOBILEATHER PROFILO)

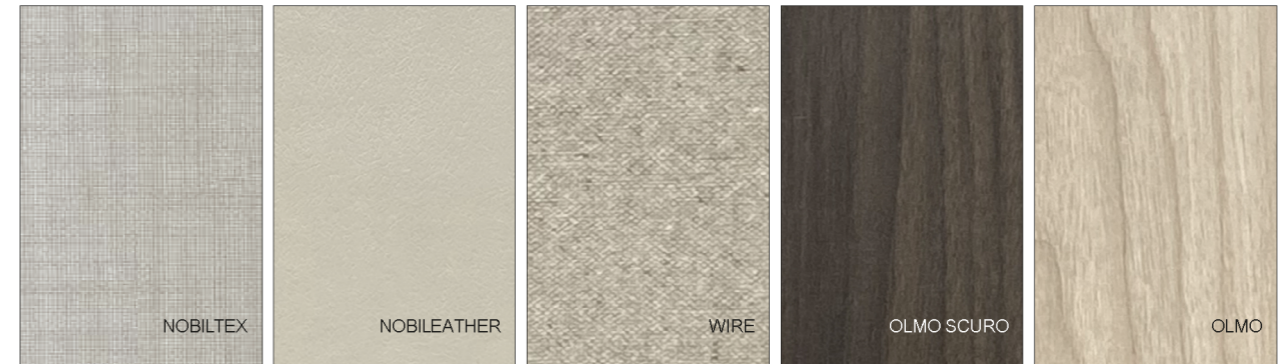

NOBILITATI attrezzature interne - MELAMINE internal equipment



ESSENZE ante - WOODS door

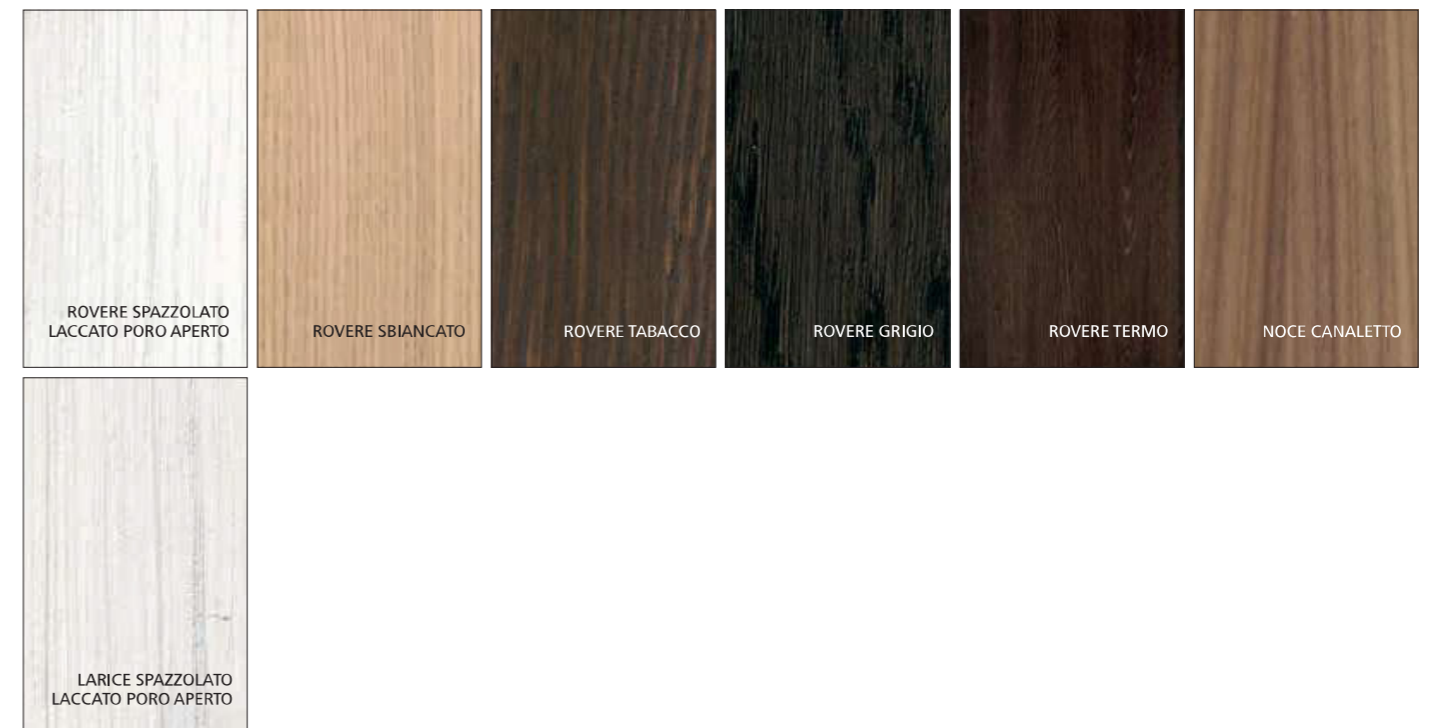

PARTI METALLICHE INTERNO ARMADIO (ESCLUSO CERNIERE)  
INTERNAL WARDROBE METALLIC ACCESSOIRES (EXCLUDED HINGES)



FINITURA STRUTTURA INTERNA PER CASSETTI  
INTERNAL STRUCTURE FINISHING FOR DRAWERS

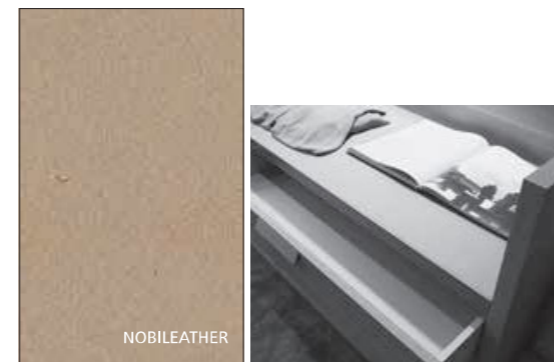

LACCATO OPACO - LACCATO LUCIDO - ROVERE SPAZZOLATO LACCATO PORO APERTO - LARICE SPAZZOLATO LACCATO PORO APERTO  
 MATT LACQUERED - GLOSSY LACQUERED - OPEN-PORE LACQUERED BRUSHED OAK - OPEN-PORE LACQUERED BRUSHED LARCH

M28 BIANCO	M30 GHIACCIO	M29 BURRO	M45 AVORIO	M08 PANNA	M66 CORDA
M02 QUARZO	M83 PERLA	M35 AZZURRO POLVERE	M10 MUSCHIO	M81 CANAPA	M67 TORTORA
M07 DESERTO	M90 ARENA	M84 CASTORO	M03 TALPA	M86 PIOGGIA	M70 SILVER
M79 ARDESIA	M75 ROSSO	M76 CARDINALE	M91 TERRA	M89 FANGO	M04 MARRONE
M11 MOKA	M88 PRUSSIA	M36 BLU AVIO	M82 GRAFITE	M06 ANTRACITE	M33 NERO

VETRI TRASPARENTI O ACIDATI - TRANSPARENT OR ETCHED GLASSES

VT TRASPARENTE EXTRA BIANCO	VTF TRASPARENTE FUMÉ	VTB TRASPARENTE BRONZO	VA ACIDATO EXTRA BIANCO	VAF ACIDATO FUMÉ	VAB ACIDATO BRONZO
-----------------------------	----------------------	------------------------	-------------------------	------------------	--------------------

SPECCHI - MIRRORS

VES SPECCHIO BIANCO	VESF SPECCHIO FUMÉ	VESB SPECCHIO BRONZO
---------------------	--------------------	----------------------

VETRO LACCATO LUCIDO O LACCATO OPACO - GLOSSY OR MATT LACQUERED GLASS

VE28 BIANCO EXTRACHIARO	VE83 PERLA	VE66 CORDA	VE67 TORTORA	VE79 ARDESIA	VE90 ARENA
VE76 CARDINALE	VE11 MOKA	VE33 NERO			

VETRO EXTRA - EXTRA GLASS

VERT RIFLETTENTE BIANCO	VERF RIFLETTENTE FUMÉ	VERB RIFLETTENTE BRONZO
-------------------------	-----------------------	-------------------------



CUOIO (ante e cassetti) - LEATHER (doors and drawers)



FINITURE EXTRA (schienali armadio e cabina armadio METROS) - EXTRA FINISHES (METROS back wardrobe and cabinets)

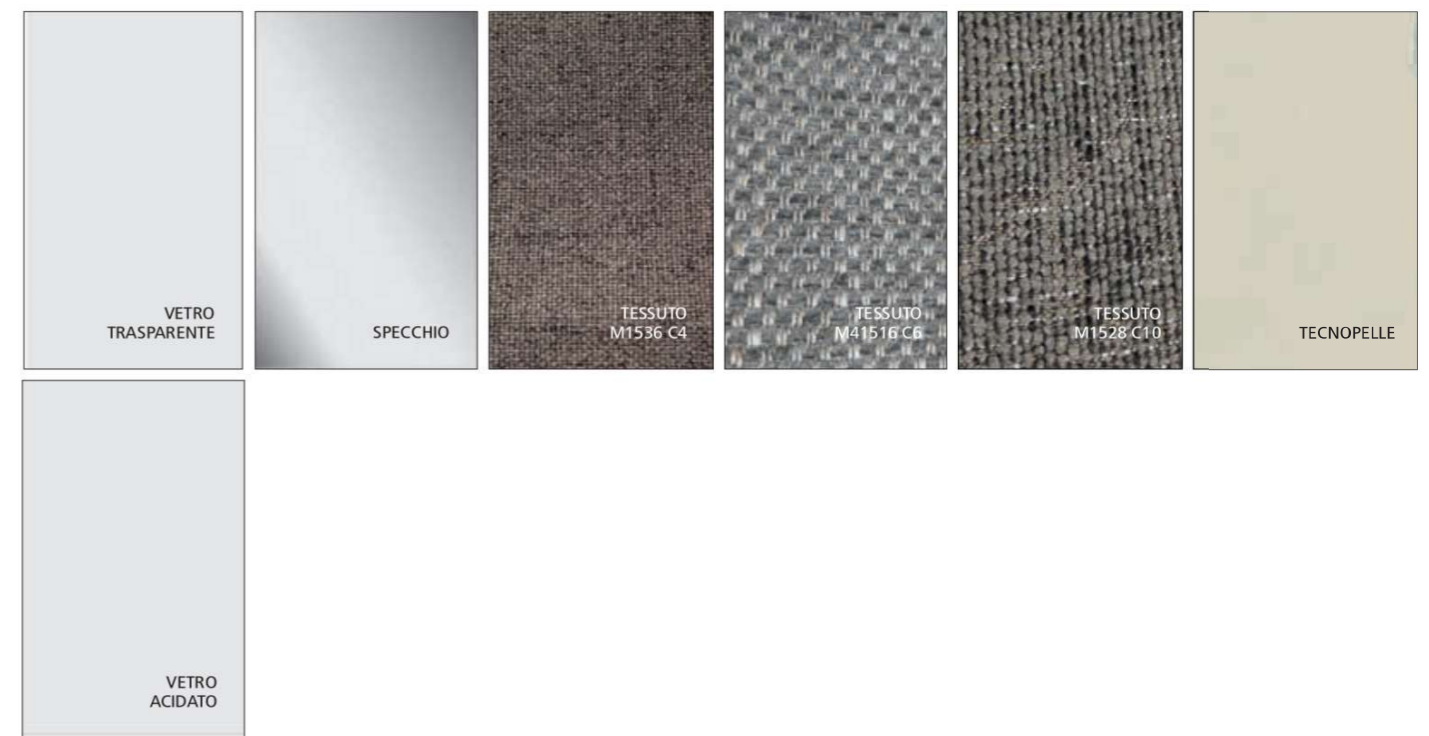

TECNOPELLE (ante, ripiani, schienali, cassetti, fondo cassetti e maniglie) - ECO-LEATHER (doors, shelves, backs, drawers, bottom drawers and handles)



ZOCCOLO BATTENTE - HINGED PLINTH



PROFILI ANTE IN METALLO - METAL DOORS PROFILES (VIEW - TECNO - FILO - LINEAR - UNI - NOBILEATHER PROFILO - MODULAR - ESSENTIAL - METAL)

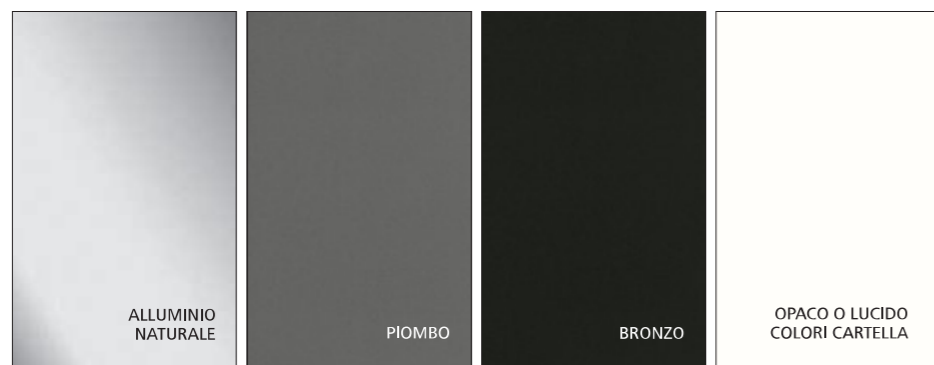

BINARIO SCORREVOLE - SLIDING RAIL

